

AS0222-5G

LNA 4.9 GHz – 7.2 GHz



DESCRIPTION

The Argo Semi AS0222-5G IP is a Low Noise Amplifier operating at frequency range between 4.9 GHz and 7.2 GHz. Target is high end applications like WiFi 6/6E/7. It can provide a max gain of 20.9 dB scalable by 6 dB steps and input compression point of -24.28 dBm at max gain. It includes functionality such as bypass mode and 4 bit biasing control circuit. Also, includes input/output WRSSI circuits for the protection and monitoring of the output power. Input is terminated to 50 Ohm.

APPLICATIONS

- WiFi 6/6E
- Wifi 7

FEAUTES

- ✓ Low Noise figure: 2.37 dB
- ✓ Operating frequency range: 4.9 GHz – 7.2 GHz
- ✓ High max gain: 20.9 dB
- ✓ IIP3: -13.74 dBm
- ✓ Input 1dB CP: -24.28 dBm
- ✓ Unconditionally stable
- ✓ Programmable bias current & gain setting
- ✓ Input/output WRSSI circuits included
- ✓ TDD systems supported
- ✓ Single supply 1V, consumption: 12.2 mA
- ✓ Technology node: GF 22FDX CMOS SOI

ABOUT ARGO SEMICONDUCTORS

Argo Semiconductors offers high quality RF IP products operating in the frequency region between 2 GHz and 10 GHz. Argo’s team has a long experience on Wi-Fi RF silicon product development and cellular RF silicon product development, bringing billions of chips to the market. Leveraging on these capabilities and building on its solid IP base, Argo helps its customers develop products that can meet the most stringent requirements, while shrinking the development time. IP customization is possible upon request.

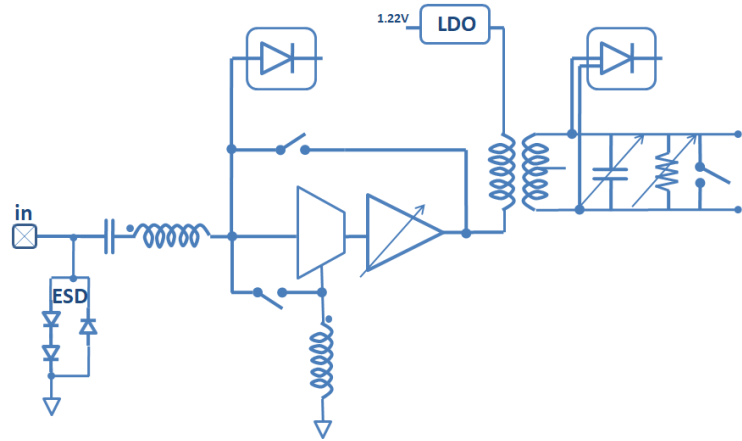

Simplified Block Diagram

LNA 4.9GHz - 7.2GHz Characteristics					
Parameter	Minimum	Typical	Maximum	Units	Comments
Operating frequency range	4900		7200	MHz	
Operating temperature range	-40		110	°C	
Noise figure (de-embedded)	1.06	1.8		dB	external inductor (@ 80/160 MHz)
	1.63	2.37		dB	internal inductor (@ 80/160 MHz)
	1.25	1.99		dB	external LNA(10dB gain/1.5dB NF) (@ 80/160 MHz)
Gain	-7.45	20.9	25	dB	
Gain step			6	dB	
Input referred 1 dB Compression point	-25.02	-24.28	-21.56	dBm	at max gain
IIP3		-13.74		dBm	at max gain
Input return loss (S11)	-11	-18.4		dB	
Drain Voltage		1		V	output of LDO after external 1.22V DC-DC converter
Input tolerance		5		dBm	5 for 0.2 years (>5dBm to be handled by input WRSSI)
Power consumption			12.2	mW	10mA from 1.22V
Area		0.317		mm ²	